

AACER™

SPORTS FLOORING

AacerChannel™ VLP HC

The AacerChannel™ VLP HC performance sports floor system provides the resiliency and safety of a floating floor and the stability of an anchored system. The floor's 100% factory assembled panels utilizing sectional Acer Hat Channel ensures uniform performance and fast installation. This system is ideal for facility retrofit projects and facilities requiring lower profiles. AacerChannel™ VLP HC is fully EN14904, DIN18032-2 and MFMA PUR Compliant.



see us at
Sweets.com



The mark of responsible forestry

FIXED RESILIENT



AacerChannel™ VLP HC

AacerChannel™ VLP HC is a fixed resilient sports performance floor system that features a monolithic subfloor with full flex and a full-thickness APA engineered underlayment to maximize system performance. The result is a DIN, EN and PUR compliant floor with increased stability, shock absorbency, energy return and **low vibration**.

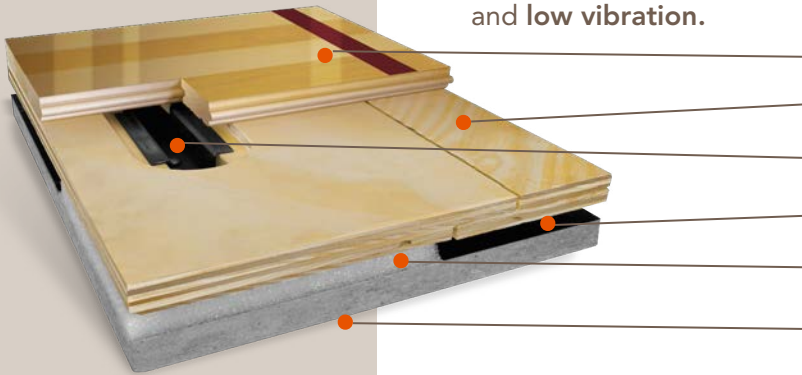

- ① Precision milled Aacer Maple
- ② Integrated Panels form a Monolithic Subfloor
- ③ Collared Steel Drive Pin
- ④ 6mil polyethylene Vapor Barrier
- ⑤ Performance Foam
- ⑥ Concrete

Anchorage	Drill and Pin
Certified	
Green Status LEED Contributors	<p>FSC® Certified Maple - MRC7 FSC® Certified Subfloor Components - MRC7 EQ - 4.2 Regional Materials - MRC5.1 & 5.2</p>
Resilience	Continuous Performance Foam Strips <i>*Contact your Regional Sales Manager for other options</i>
Slab Depression	1/2" (12mm) Performance Foam 25/32" (20mm) flooring - 1 7/8" (48mm) 33/32" (26mm) flooring - 2 1/8" (54mm)
Subfloor Construction	Pre-manufactured panels
System Type	Fixed Resilient
Testing Laboratory	
U.S. Patent#	#5,647,183
Warranty	Lifetime available

WALL BASE

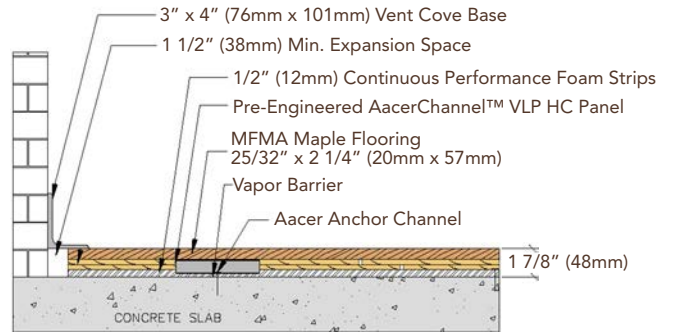

THRESHOLD

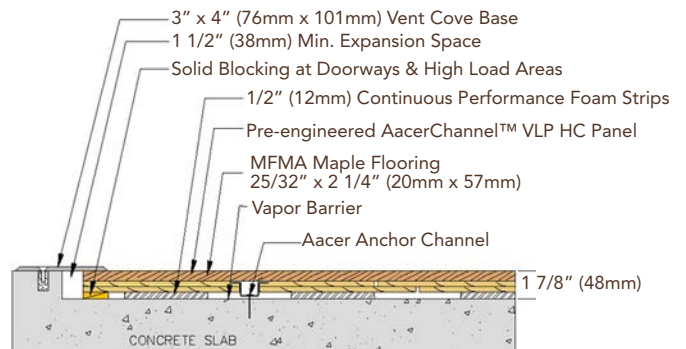

EQUIPMENT

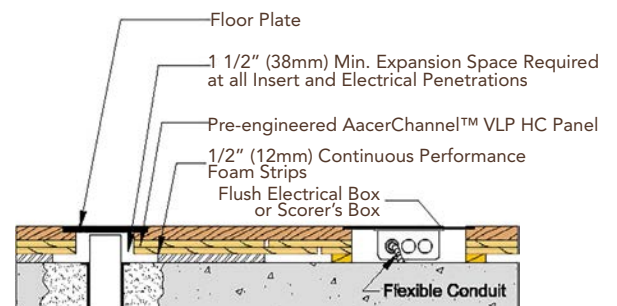

AacerFlooring.com

877.582.1181

It is the policy of Aacer Flooring to continuously improve its line of products. Therefore, Aacer Flooring reserves the right to change, modify or discontinue systems, specifications and accessories of all products at any time without notice or obligation to purchaser.

May 2016