



AACER™

SPORTS FLOORING

AacerChannel™ LP

A high performance sports floor system with the resiliency and safety of a floating floor and the stability of an anchored system. This unique combination is ideal for large field houses and combination wood and synthetic facilities.



see us at
Sweets.com



The mark of responsible forestry

FIXED RESILIENT



AacerChannel™ LP

AacerChannel™ LP enhances performance in gymnasiums, dance floors and multipurpose facilities.



- 1 Precision milled Acer Maple
- 2 Integrated Panels form a Monolithic Subfloor
- 3 TriPower™ Pad
- 4 16 gauge steel anchored to concrete
- 5 6mil polyethylene Vapor Barrier
- 6 Concrete

Anchorage	Drill and Pin
Certified	
Green Status LEED Contributors	<p>FSC® Certified Maple - MRC7 FSC® Certified Subfloor Components - MRC7 EQ - 4.2 Regional Materials - MRC5.1 & 5.2</p>
Optional Version	AacerChannel
Resilience	TriPower™ Pads <i>*other options available</i>
Slab Depression	<p>3/4" (19mm) TriPower™ Pads 25/32" (20mm) flooring - 2 1/2" (64mm) 33/32" (26mm) flooring - 2 3/4" (70mm)</p> <p>AacerChannel LP with 1/2" (12mm) TriPower™ Pads 25/32" (20mm) flooring - 2 1/4" (57mm) 33/32" (26mm) flooring - 2 1/2" (64mm)</p>
Subfloor Construction	Pre-manufactured panels
System Type	Fixed Resilient
Testing Laboratory	
U.S. Patent#	#5,647,183
Warranty	Lifetime available

WALL BASE

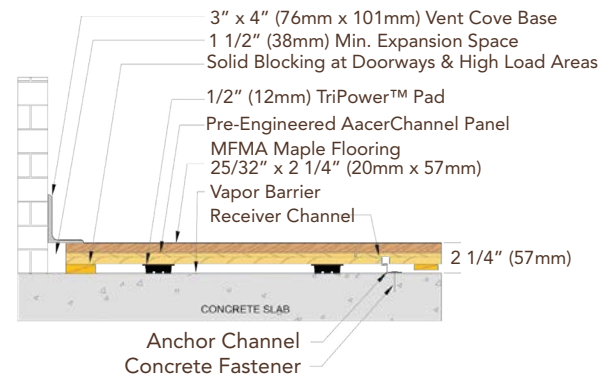

THRESHOLD

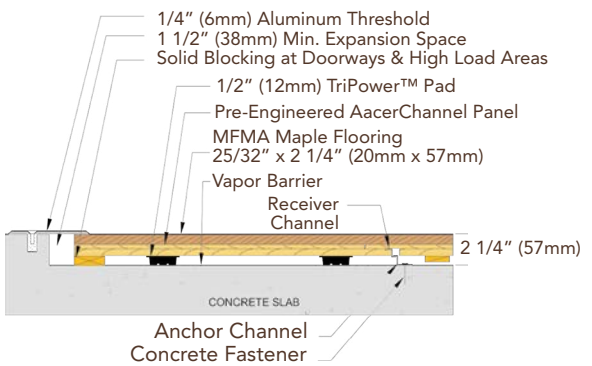

EQUIPMENT

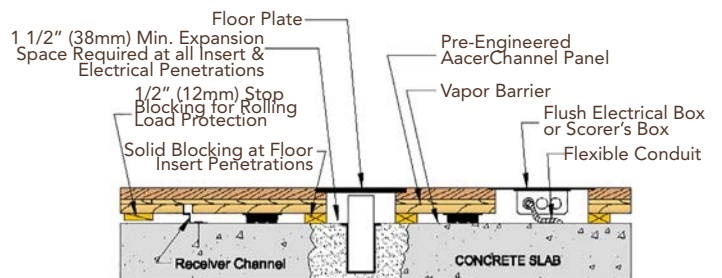

AacerFlooring.com

877.582.1181

It is the policy of Aacer Flooring to continuously improve its line of products. Therefore, Aacer Flooring reserves the right to change, modify or discontinue systems, specifications and accessories of all products at any time without notice or obligation to purchaser.

May 2016