



AACER

SPORTS FLOORING

PowerVent™ Airflow System

Whether designing a new facility or concerned about moisture in an existing facility, turn to Aacer's PowerVent Airflow system. The PowerVent Airflow system mechanically forces airflow through the floor system to help prevent or alleviate moisture issues.

"We were amazed that when 1,000 gallons of water flooded our gym floor from a broken sprinkler head, the PowerVent™ Air Flow system handled it beautifully. We were able to keep right on serving our members by using the facility without any major interruptions. The floor still looks and performs just great."

– Denise Day, Executive Director
Kennett Area YMCA, Kennett Square, PA

"The ScissorLoc™ system and humidistat controlled blowers certainly provide us with the necessary air flow to alleviate our concerns about a moisture problem."

– Robert Duncan - Superintendent
Reading Community Schools



see us at
Sweets.com



The mark of responsible forestry

ACCESSORY



PowerVent™ Airflow System

Aacer's PowerVent™ Airflow patented design features an exclusive under floor detection system. Should the under floor humidistat detect moisture, it will trigger fan units to start circulating air through the floor system before it is noticeable to facility personnel. The PowerVent™ Airflow system has saved several floors from failure.



Benefits

- Automatically detects moisture and initiates drying process.
- Inhibits the growth of mold.
- Allows airflow to all layers of the floor system.
- Multiple blowers for full coverage.
- Maintains stability and uniform performance.
- Prevents costly shutdowns. Floor can continue to be used while drying.
- Can be added on after original construction.
- Can be fit to any floor system.
- Security and ease of mind for owners.

WALL

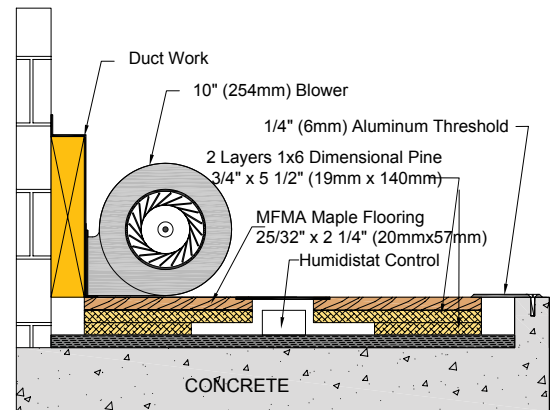

OVERHEAD VIEW

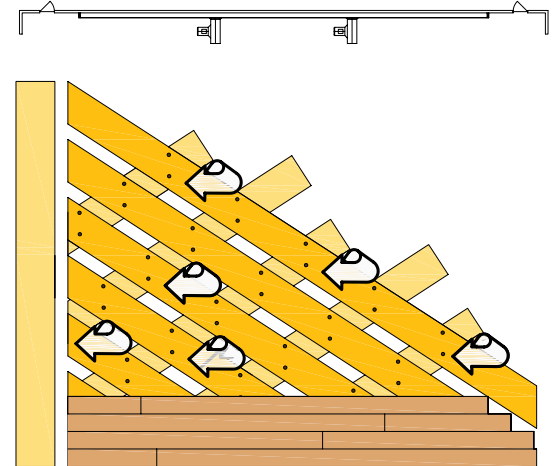

U.S. Patent

#5,526,621

Moisture trapped between the concrete slab and the wood floor often causes the floor to excessively expand and contract. PowerVent™ Airflow's performance engineered subfloor provides a natural criss-cross air flow that significantly reduces problems associated with excess moisture. Most importantly, an Automatic Mechanical Air Flow device also helps to prevent moisture damage to the floor system. This automatic feature on the PowerVent™ Air Flow system is extremely beneficial and necessary during those times when no one is present to detect a moisture problem or catastrophe. Give your sports floor the ability to beat moisture. Specify the PowerVent™ Airflow system - the big winner in the battle against moisture.

AacerFlooring.com (877) 582-1181

It is the policy of Aacer Flooring to continuously improve its line of products. Therefore, Aacer Flooring reserves the right to change, modify or discontinue systems, specifications and accessories of all products at any time without notice or obligation to purchaser.

August 2014